

**EEMODS 2011 - Paper 060****Achieving High Electric Motor Efficiency**  
**John Petro, Chief Technical Officer, NovaTorque, Inc.****ABSTRACT**

*Permanent Magnet (PM) motors made with ferrite magnets can significantly exceed the current NEMA Premium and IE3 efficiency standards and even the proposed future IE4 motor efficiency standards while still being highly cost-effective in the marketplace. This is made possible by using motor geometries that allow for flux concentration from the ferrite magnet components. The use of motor structures which can concentrate magnetic flux allows ferrite PM motors to achieve performance and power densities that approach those of PM motors using rare earth magnets, but without the cost penalties and supply source concerns of rare earth magnets.*

*Currently, ferrite PM motors with a 2.2 kilowatt rating are operating at 93 percent efficiency, compared to the IE3 standard of 89.5 percent. In addition, these motors maintain high efficiency over a broad range of speed and torque values. It is estimated that these motors can be further improved to have efficiencies of above 94 percent in the near future. The development path and design approaches to achieve such efficiencies will be discussed. This paper will present design projections of performance results from a range of motors and, in addition, provide measured results when they become available. The outstanding efficiency improvement provided by these motors will be compared to existing motor solutions that are currently available on the market, and the overall energy savings will be illustrated.*

**BACKGROUND**

The need to increase overall motor system efficiency has never been greater. With the rising costs of energy and the substantial concerns about global CO2 emissions, achieving the highest possible motor system efficiency has become a critical priority.

In almost all cases, the addition of a variable-speed drive to an electric motor system leads to substantial energy savings by allowing motor speed and load to be optimized to the system requirements. The efficiency of the variable-speed electronic drive portion of a modern motor system is very high: almost always above 95 percent, often 97 percent, and recent improvements are pushing drive efficiencies to 98 percent and higher. These high efficiencies for variable-speed drives can be achieved over a wide range of motor speeds and loads.

However, even at these high efficiencies, the addition of a drive to a line-operated motor still reduces the peak efficiency of the motor system. In addition, induction motor efficiency is specified under sinewave line operation and, when operated using an electronic drive, the induction motor efficiency is usually degraded, further reducing the overall system efficiency. If an induction motor is only used at its rated speed and torque, then adding a drive will actually reduce the overall system efficiency. However, in real world applications, operation at only this one speed and load is rarely the case, which is why adding a variable-speed drive usually results in increased system efficiency.

Given how high drive efficiencies already are, there is very little room for improvement to overall motor system efficiency with additional drive improvements. Therefore, it is essential to improve the efficiency of the motors used with variable-speed drives. Indeed, motor efficiency improvements are critical if overall motor system efficiency is to be increased in any substantial manner.

Of course, any increase in motor efficiency must be balanced with the cost of the motor. While very high efficiency motors can be achieved using exotic materials and manufacturing processes, the high price of such motors greatly limit the applications that can adopt such a motor.

It would clearly be far better to achieve high motor efficiency while using lower cost materials and manufacturing processes.

It is well-accepted that permanent magnet motors can achieve higher motor efficiencies than induction motors because of the reduction of losses in the rotor. In addition, the rated efficiency of a permanent magnet motor is specified with the assumption it will be operated from an electronic drive, so its rated efficiency performance can actually be achieved in real world applications. However, permanent magnet motors in the past have cost more than induction motors due to the cost of the magnet materials used in these motors. This is especially a concern at the present time since many high performance permanent magnet motors rely on rare earth permanent magnet materials, which are experiencing unprecedented price increases and supply problems.

Permanent magnet motors are also generally more power dense than induction motors, which results in using less electrical steel and conductor material to manufacture a motor of equivalent output power. Given that permanent magnet motors can be constructed using less steel and conductor material for the same output power, the additional cost of a permanent magnet motor is clearly attributable to the cost of the permanent magnet materials in these motors.

While most new high performance permanent magnet motors use rare earth-based permanent magnets (neodymium iron boron formulations), these are not the only permanent magnets that can be utilized in constructing a permanent magnet motor. In fact, most small permanent magnet motors utilize low-cost ferrite magnets as the permanent magnet field source. Such motors are widely used in many applications in automobiles, motion control systems and toys. Many of these motors are brush type motors, but brushless motors have been widely used in fans, disk drives and many motion control applications. This paper focuses on the design considerations for integral horsepower brushless permanent magnet motors.

The problem with ferrite permanent magnets is that their power density is only about one-third the power density of rare earth-based permanent magnets. This generally results in either a motor with less performance or a motor that is substantially larger and, therefore, uses more electrical steel and conductor material. However, with the recent concerns over rare earth permanent magnet materials, there has been a resurgence of interest in ferrite-based permanent magnet motors. Especially since ferrite magnet material is selling at prices less than one-tenth the cost of rare earth magnets and since there is a wide range of supply sources for these magnets, this recent interest is likely to intensify.

## **LOSS SOURCES IN PERMANENT MAGNET MOTORS**

To achieve high motor efficiency, careful attention must be paid to all sources of loss in a motor. A motor designer should take advantage of any inherent performance characteristics of different motor geometries to achieve the goal of a high efficiency motor with low material and manufacturing costs.

Motor efficiency is inversely related to the total amount of power losses in the motor. Motor losses are often divided into two major areas: conduction losses and speed-related losses. Conduction losses are the result of the motor drive current flowing in the motor coils with a finite resistance. These losses are related to the motor current squared times the motor resistance ( $I^2R$ ). All of the conduction losses occur in the stator of a brushless permanent magnet motor. The speed-related losses consist of iron losses, hysteresis and eddy currents in the motor components, frictional losses from the bearings, and windage. Iron losses can occur in both the stator and the rotor of the motor. Frictional losses are all related to the rotor of the motor.

A last category of losses is other losses that depend both on torque and speed and especially occur in the extremes of motor operation. These losses are generally related to magnetic nonlinearities which increase harmonics, hysteresis and eddy current losses at a rate that is faster than predicted by normal operating conditions.

Conduction losses generally dominate the efficiency performance of a motor when the motor is operated at lower speeds. Iron losses generally set the efficiency performance at high speeds. To achieve a broad flat efficiency curve, both conduction and iron losses must be addressed and kept at

a low value. Motor losses are summarized in Table 1 below.

	<u>Location</u>
<b>Conduction losses – torque-related losses</b> Coil $I^2R$ losses	stator
<b>Speed losses – speed-related losses</b> Iron losses – hysteresis and eddy currents	stator and rotor
Frictional losses – bearings and windage	rotor
<b>Other – torque and speed related</b> Excess losses – hysteresis and eddy currents	stator and rotor

**Table 1: Motor Loss Summary**

## MOTOR DESIGN: RADIAL AND AXIAL WINDINGS

For low speed operation, such as most typical fans, conduction losses will be of primary importance. Conduction losses are directly related to the volume of conductor that can be incorporated into the motor. Radial and axial motors differ greatly in the way additional conductor is added to the motor.

In a radial motor the amount of conductor is limited by the slot width available in the tooth design; see Figure 1A below. As the slot width is increased to allow for more conductor area, the amount of flux that can be carried by the tooth is decreased. Since the torque of a motor is directly set by the amount of flux linked by the ampere turns of the coil, this creates a no-win tradeoff with respect to efficiency.

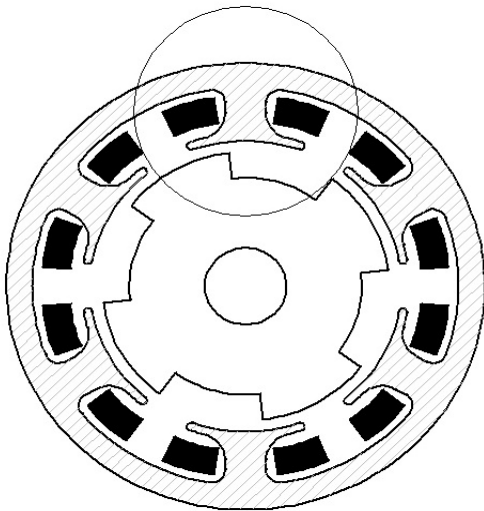

**Figure 1A: Radial motor winding**

In the radial motor design, more flux per turn can be obtained by increasing the length of the motor, but this makes the winding shape more rectangular. Rectangular windings have a longer winding perimeter for the amount of enclosed area and, therefore, higher winding resistance as shown in Figure 1B. The area enclosed by the winding is shown as  $A_r$  and the perimeter of the winding is  $P_r$ .

Rectangular winding extends  
for the length of motor

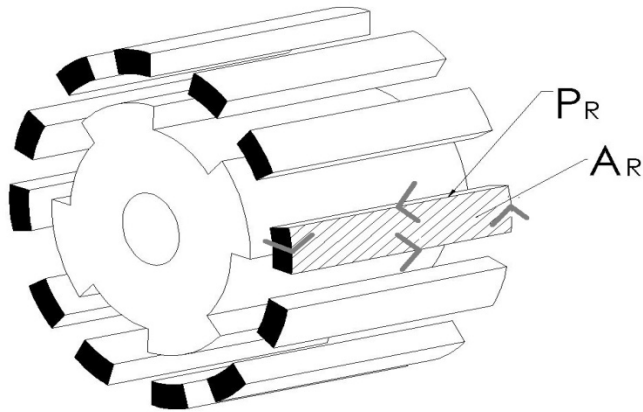

**Figure 1B: Radial motor winding**

In an axial motor, the winding shape can be designed so that it is nearly circular, as shown in Figure 2. A circular winding encloses the maximum possible area for a given winding perimeter, thereby minimizing winding resistance. The area enclosed is shown as  $A_N$  and the perimeter as  $P_N$ . In an axial motor design, the addition of more conductor volume is relatively straightforward. In this type of motor, the conductor volume can be increased by simply lengthening the linear coil dimension and the overall motor. While this does increase the amount of iron in the stator, at low speeds it does not lead to significant increase in iron losses compared to the decrease in the conduction losses. As the available conductor volume is increased, a wire having a larger cross sectional area can be used while keeping the number of turns constant, which reduces the winding resistance. This technique to lower conduction losses can be applied until the cost of the increased material volume is uneconomic or the additional iron losses negate the lower conduction losses.

Nearly circular winding

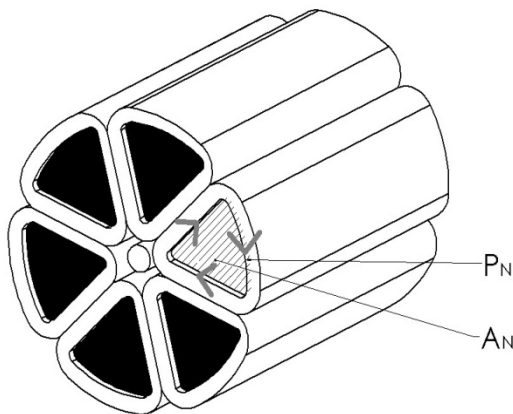

**Figure 2: Axial motor winding**

## MOTOR DESIGN: BACK EMF WAVEFORM

When designing a motor for high efficiency, the often discussed choice between sinewave and trapezoidal back electro-motive-force (EMF) waveforms is relatively easily resolved. A trapezoidal back EMF waveform means that the motor naturally has higher harmonic content. As a motor approaches a pure sinewave back EMF, the harmonics approach zero. Since hysteresis losses are directly related to frequency, and eddy current losses are proportional to frequency squared, it is important to minimize higher frequency content in the motor to achieve low losses and high efficiency. Therefore, it becomes obvious that a high efficiency motor should be designed to minimize harmonic content as much as possible. A high efficiency motor should be designed so that the magnetic flux in the stator is sinusoidal versus rotation angle at no load. Under excitation this sinusoidal condition should also be maintained as the motor is taken from no load to full load.

While it is often asserted that a motor with trapezoidal back EMF driven with a trapezoidal drive waveform delivers more output torque than an equivalent-sized motor with a sinewave back EMF operating with a drive with a sinewave drive waveform, the sinewave solution can have lower losses and higher efficiency. Also, the higher power assertion of the trapezoidal solution may be true in an instantaneous condition, but it does not consider the thermal limit of the motor, which is set by the motor losses. Indeed, most motors are limited in power output by their thermal limit and not by inherent magnetic or other physical limitations.

## **MOTOR DESIGN: POLE COUNT**

If a motor is going to generally be operated at high speeds, it is much more important to ensure that the motor iron losses are minimized. If, on the other hand, a motor is designed for low speed operation such as some direct drive fan applications, the conduction losses must be considered foremost by the motor designer.

The pole count of the motor must be considered here. As pole count increases, the motor frequency increases, leading to higher iron losses. For low speed applications, a high pole count motor can be used since the speed losses will not be of overriding concern. For high speed applications, a low pole count motor may be the best choice so that the speed losses can be minimized and efficiency kept high.

## **MOTOR DESIGN: MAGNET TYPE**

There are two types of permanent magnets commonly used in motors. Until the last decade the most common magnet type was ferrite magnets. Over the last 10 years most new permanent magnet motors moved to rare earth type permanent magnets (neodymium-iron-boron formulations) because they have a much higher flux output and energy product. The cost of these rare earth magnets dropped for many years until the price was competitive to ferrite on an overall performance basis. However, during the last two years, unprecedented price increases have occurred in this type of magnet which has resulted in a return to ferrite permanent magnet motor designs.

Ferrite magnets are considerably weaker than most rare earth magnets. Typical ferrite magnets have a Br of about 3800 gauss compared to about 10,000 gauss of a rare earth style permanent magnet. The coercivity of ferrite magnets also is proportionally lower. This results in an energy product for ferrite that is about 1/8 to 1/10 that of rare earth magnets. This is why flux concentration is so important with ferrite magnets. However, magnet volume for a motor is dependent on the flux ratio and not on the energy product ratio, so the volume of ferrite magnet material needed for equivalent performance is only about 3 times the volume of rare earth magnet for similar flux output.

Since the coercivity of ferrite magnets is low, care must be taken in the motor design to prevent the energized coils of the motor from causing demagnetization of the magnets in fault conditions. However, the coercivity of a ferrite magnet increases with temperature, so demagnetization is most likely to occur when the motor is cold.

All magnets lose flux strength with increasing temperature and ferrite unfortunately experiences about twice as much flux loss with each increment of temperature compared with a typical rare earth type magnet.

The mechanical strength of ferrite and rare earth magnets is about the same. Several advantages of ferrite magnets compared to neodymium-iron-boron magnets include (1) they are non-conducting so they do not have eddy current losses associated with them and (2) they are corrosion resistant and therefore do not need to be coated with any protective coating.

## **MOTOR DESIGN: AXIAL MOTOR FLUX CONCENTRATION**

For a ferrite magnet motor to achieve the high power density and performance of a motor designed with rare earth magnets, flux concentration must be employed. Flux concentration is

achieved in several ways in a motor.

One method of flux concentration is to use an interior permanent magnet design where the magnet surface areas are greater than the pole piece surface area. This is best illustrated in Figure 3 below. A radial spoke type IPM structure is utilized to increase the total magnet surface area that feeds flux to the pole piece. A magnet with surface area  $B_m$  sits on each side of a pole piece so the flux area into the pole piece is 2 times  $B_p$ . This flux is concentrated into an area of the pole piece of  $A_{MP}$ . Of course only so much flux concentration can be obtained this way, since the magnets feeding the pole piece are in opposition, which lowers their load line, thereby reducing their effective flux output.

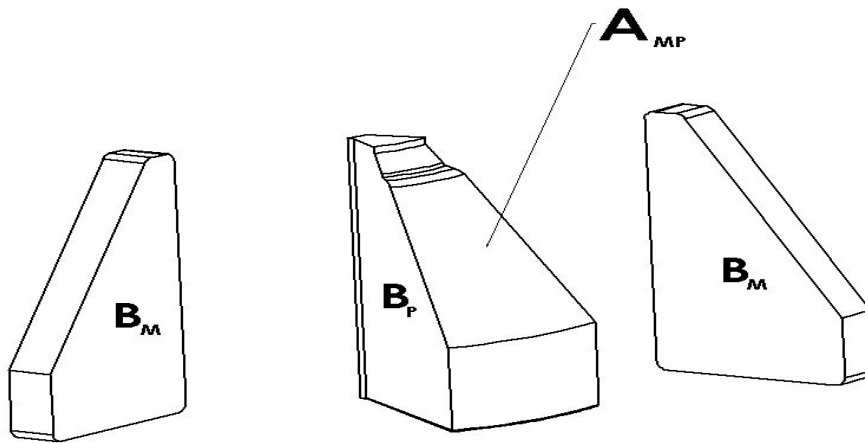

**Figure 3: IPM spoke type flux concentration**

To further enhance the concentration of flux into the active pole of a motor, a conical rotor structure can be implemented for an axial motor. This cuts the axial field pole at an angle, increasing the surface area available compared to the axial flux carrying area of the field pole core. See Figure 4 below. With this design the magnet surface area  $A_{FP}$  is greater than the field pole cross sectional core area  $A_{CS}$ . This provides flux concentration proportional to the ratio of the two areas. Combining both techniques increases the flux available from a ferrite magnet to near rare earth magnet levels and results in a high performance motor with low magnet costs.

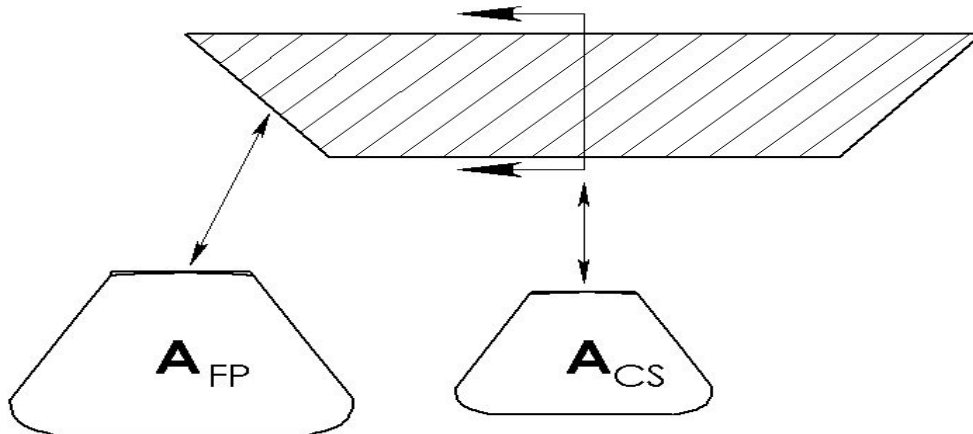

**Figure 4: Conical motor flux concentration**

## MOTOR DESIGN: MAGNET CONFIGURATION

Another important permanent magnet design issue is the choice between surface-mounted and interior located permanent magnets (IPM) on the rotor. Ideally, for a surface-mounted PM

machine, the flux in the rotor does not undergo any change with rotation under any condition. In this condition, there are no hysteresis or eddy current losses in the rotor. This allows the use of a solid core for the return path flux in the rotor without any penalty of additional rotor losses. However, if the flux output of the rotor changes as it rotates due to tooth gaps or other reluctance path variations, this can result in losses in the rotor. In general, surface-mounted magnet motors can be designed to have very little rotor loss.

IPM motor designs are proving to be highly desirable because they can reduce the speed limitation that is inherent to permanent magnet motors when surface-mounted designs are employed. This IPM design uses both permanent magnet torque and reluctance torque to create a motor with many highly desirable characteristics.

As with surface-mounted motors, the IPM motor should have a sinusoidal back EMF in the stator and should ideally have sinusoidal flux throughout the motor. However, given the use of reluctance torque in this style of motor, it is impossible to avoid flux changes in the rotor soft magnetic structure. This changing flux in the rotor therefore requires the rotor to have a laminated or highly resistive material to limit eddy current losses in the rotor. This flux change also leads to hysteresis losses in the rotor. So with IPM motor designs, losses in the rotor cannot be avoided and must be taken into account in any thermal modeling of the motor.

## MOTOR DESIGN: RADIAL AND AXIAL TORQUE SCALING

There is another fundamental difference between radial and axial permanent magnet motor configurations. This notable and often misunderstood difference is the relationship of output torque with respect to motor diameter.

In all cases, torque is the result of force applied at a radius. In all motors, the radius increases directly with the increase in diameter of the motor, resulting in a linear increase in torque with diameter solely due to the increased radius. Also, in a permanent magnet motor, the available force is directly proportional to the flux-carrying capability of the stator. So, as diameter increases and the amount of flux that can be carried in the stator increases, the torque of a motor will also increase.

With a radial motor, as diameter increases, the circumference where the stator pole shoes are located also directly increases (Figure 5). This means that the flux-carrying area of the pole shoes linearly increases with diameter. Therefore, torque increases with the square of diameter, since both the radius and the total flux are linearly increasing with motor diameter.

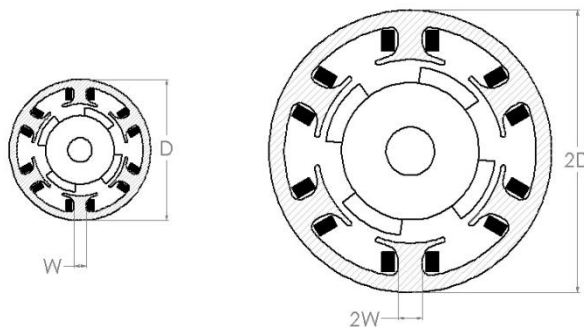

**Figure 5: Radial motor with diameter D and 2D**

In addition, for a radial motor the flux-carrying area also directly increases with stator length. Since force is directly related to total flux, increasing the motor length also increases torque in a linear manner.

Therefore, in a radial motor, torque increases with the square of diameter and also increases with additional length of the motor, resulting in an overall cubic function for torque. This results in a radial motor increasing torque proportional to the volume of the motor, since the motor volume also increases with the square of diameter and linearly with the length of the motor.

For an axial motor, the torque increases with the cube of diameter and does not increase with

motor length. The reason for this is, again, that torque is force times radius. As the axial motor diameter increases, the radius increases, so the torque increases linearly with diameter due to this radius increase. The force in an axial motor is also directly proportional to the amount of flux that the stator of the motor can handle without saturating. The amount of flux is dependent on the area of the stator, and this area increases with the square of the motor diameter. This is shown in Figure 6 below as area  $A$  and  $4A$ . Four times the area can carry four times the flux and this is the result of the stator poles increasing in two dimensions as diameter increases.

**Figure 6: Axial motor with diameter  $D$  and  $2D$**

Because the radius of the motor increases directly with motor diameter, and the force increases with the square of motor diameter, torque of an axial motor increases with the cube of diameter. Notice that since only the diameter is changing, the axial motor volume only increases by the square of the diameter, even though the torque increases by the cube of diameter. This leads to the fact that for larger motors, an axial motor can use less material to achieve the same torque, compared to a radial motor. Please note that the above is a theoretical approach, and in actual practice the length of an axial motor does need to increase somewhat with increasing diameters, since the air gap dimension, strength of materials and realistic sized bearings must be considered. This still leaves the axial motor design at an advantage over radial motor designs when compared on the basis of torque generated per unit volume of active material required.

Increasing the length of an axial motor does not provide any additional torque capability for the motor, since the flux in the stator is along the axis of the motor. Adding length to an axial motor does provide more room for additional conductor volume and more surface area for heat dissipation. Adding conductor volume can decrease the total motor resistance and thereby decrease the total conduction ( $I^2R$ ) losses of the motor. This is an excellent approach for achieving high motor efficiencies at low motor speeds and leads to a broad, flat motor efficiency curve. Of course, the extension of the length of an axial motor adds both additional stator steel and conductor material, increasing both the weight and cost of the motor. In addition, the extra stator steel adds additional iron losses in the motor, which hurts high speed efficiency performance. However, up to a limit, by using low loss electrical lamination steel in the stator, overall efficiency can be improved by adding length to an axial motor configuration.

## THERMAL CONSIDERATIONS

Another factor that affects motor efficiency is the ability of a motor to shed excess heat to the external environment. This is expressed in terms of a motor's thermal resistance. When a motor is operating near its maximum efficiency, approximately half the dissipated power is in the winding from conduction losses and the other half is in the stator iron and rotor iron. In a typical radial motor, the winding is inside the motor, leading to higher thermal resistance and lower continuous output power. With an axial motor, a major portion of the winding is exposed on the outside of the motor. This leads to a lower thermal resistance and higher operating power.

The thermal paths for a radial and axial motor are illustrated in Figure 7 and 8 below.

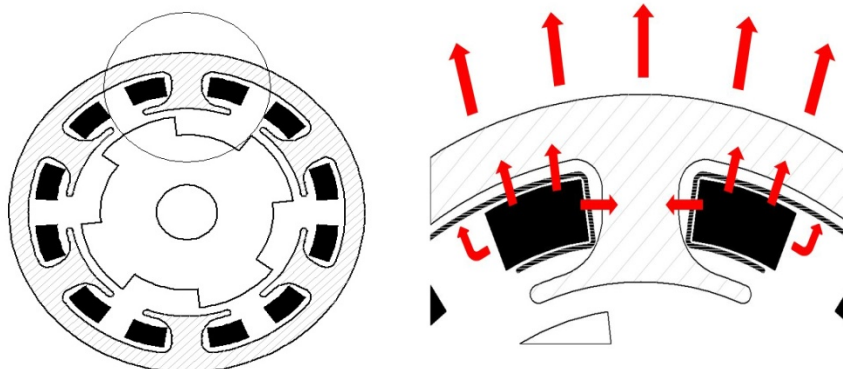

**Figure 7: Radial Motor Thermal Path**

For the radial motor the coils are inside the back iron so the heat must be transferred from the coils to the back iron and then out of the motor.

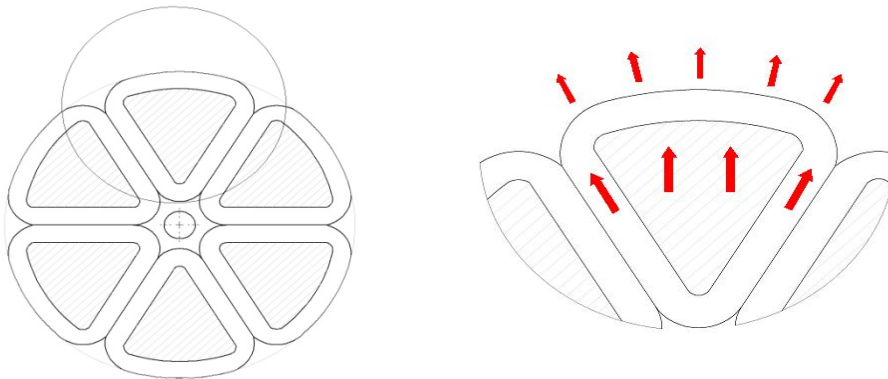

**Figure 8: Axial Motor Thermal Path**

For an axial motor a large portion of the coil resides on the outside of the field pole iron and there is no back iron. This allows access to the coil directly for more effective cooling of the motor.

## **MOTOR EFFICIENCY IMPROVES WITH INCREASED SIZE**

When considering what constitutes a high efficiency motor, the power rating and speed of the motor must be taken into account. Motor efficiency generally increases with larger physical sized motors and higher power levels. While a 1 KW machine may be considered very efficient at an 87 percent efficiency rating, a 50 KW machine would need to be 95 percent efficient to be considered highly efficient.

Efficiency improves as radial motors get larger, because motor torque increases directly with motor volume, while losses increase at a lower total rate. While iron losses scale directly with motor volume, conduction losses proportionally decrease with larger motor sizes. This is the result of the increased area having more flux carrying capability. High flux means that for the same operating voltage, fewer turns of conductor are needed to achieve the same output torque. Given that the larger size has also increased the area available for conductors, fewer turns of heavier wire can be used, which reduces the motor resistance in two ways.

For an axial motor, the output torque increases faster than the motor volume increases, so the iron losses are proportionally smaller as motor size increases. In addition, axial motors also experience reduced conduction losses proportionally as motor size increases. This gives the axial motor design an even better increase in efficiency with increased motor size.

## **EXAMPLE OF AXIAL FERRITE PERMANENT MAGNET MOTOR**

A motor implementing many of the concepts presented above has been designed and is currently being fabricated to achieve high efficiency over a broad speed and torque operating range. The actual performance of this motor will be established with exacting dynamometer testing later this summer and the measured results added to this paper. For now, estimated values are provided in brackets [ ] in the discussion below.

Figure 9 shows a picture of a brushless permanent magnet axial flux motor constructed with ferrite permanent magnets using flux concentration from both a conical air gap and interior permanent magnet rotors.

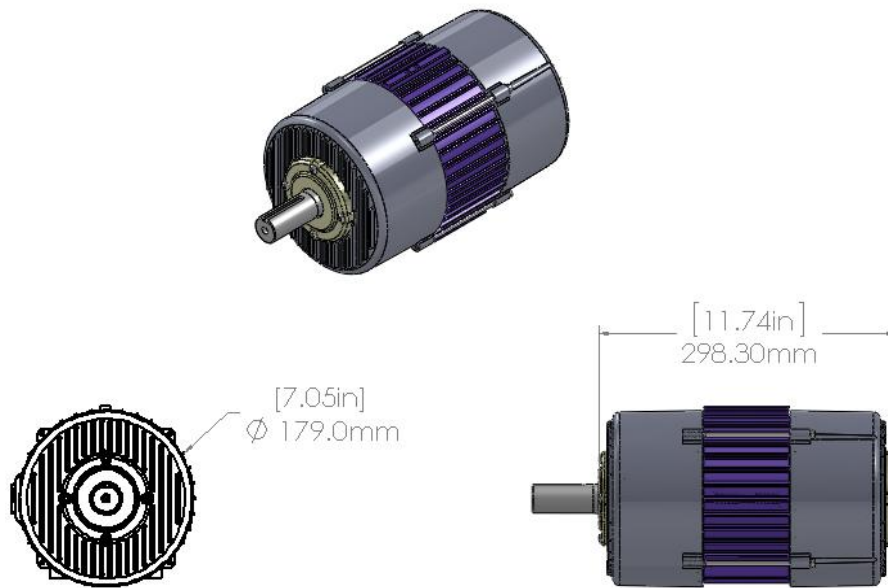

**Figure 9: Axial Permanent Magnet 3.7 Kw Motor**

The specifications and performance of this motor with ferrite magnets using flux concentration is given in Table 2.

Rated Power	3.75 Kw
Rated Speed	1800 RPM
Rated Torque	20 Nm
Peak Efficiency	93.0 %
Diameter	179 mm
Length	300 mm
Weight	30 Kg

**Table 2: Basic Motor Specifications**

This motor is a 3.7 KW (5 Hp) motor with 20 Nm of torque at 1800 rpm and runs at an efficiency of [93 to 94] percent. The efficiency is flat over a broad range of speeds and torques as shown in Figure 10. It requires only [8] kilograms of steel (including scrap), [2.2] kilograms of copper and [3.7] kilograms of ferrite magnet material. It weighs a total of [30] kilograms and has a base diameter of [179] mm and a length of [300] mm.

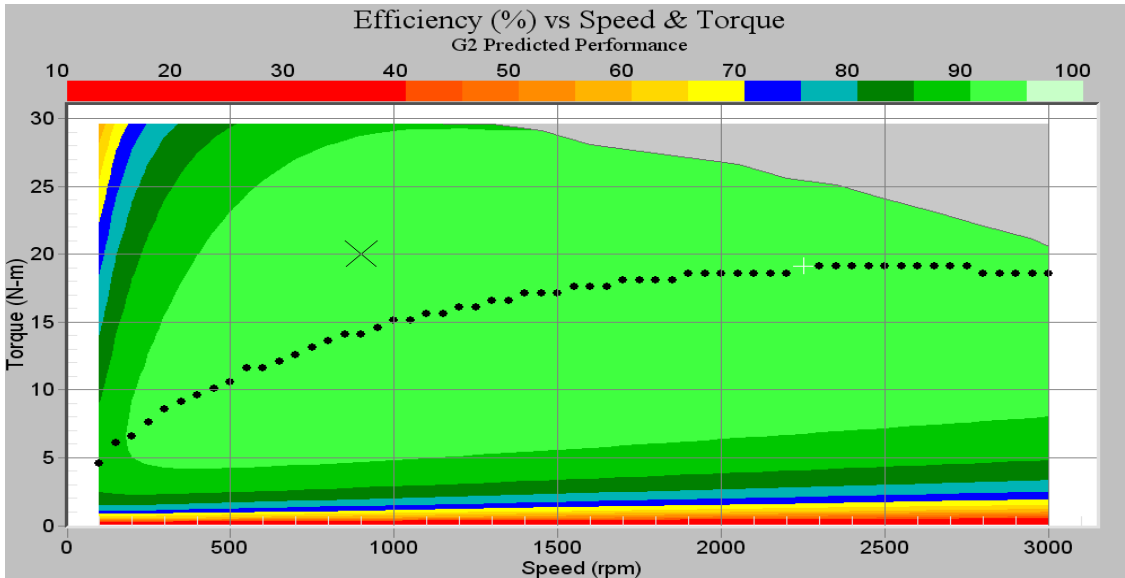

Figure 10: Predicted Motor Efficiency versus Speed and Torque for 1800 RPM Motor

In the figure above, the color bar above the graph provides a key showing the color which represents each efficiency percentage, in 5% range increments. The bright green color represents efficiencies in the 90 – 94% range. As shown in the figure, this motor is expected to be over 90% efficient at most speeds (horizontal axis) and torques (vertical axis). Efficiency over 90% over such a wide operating range of speeds and torques is exceptional for a motor of this size. Most motor designs provide such high efficiencies only near their rated load, and display a significant decrease in efficiency at lower speeds and torques.

This motor can easily be scaled to higher power ratings since the torque of this motor increases with the cube of diameter and the length of the motor is relatively constant. It can also achieve much higher rotational speeds, allowing for very high power density in applications that need high speed or can accept a gear box reduction.

For low speed applications (900 rpm maximum), a second version of this motor incorporates additional winding volume by lengthening the motor by [60] mm. Since the speed is lower, the number of turns on the winding can be increased, which reduces the required drive current. This reduction in current more than offsets the increase in winding resistance, so that the conduction losses are reduced. This then further increases the motor efficiency, and especially extends the motor efficiency to lower speed operation. This is shown in the graph of Figure 11.

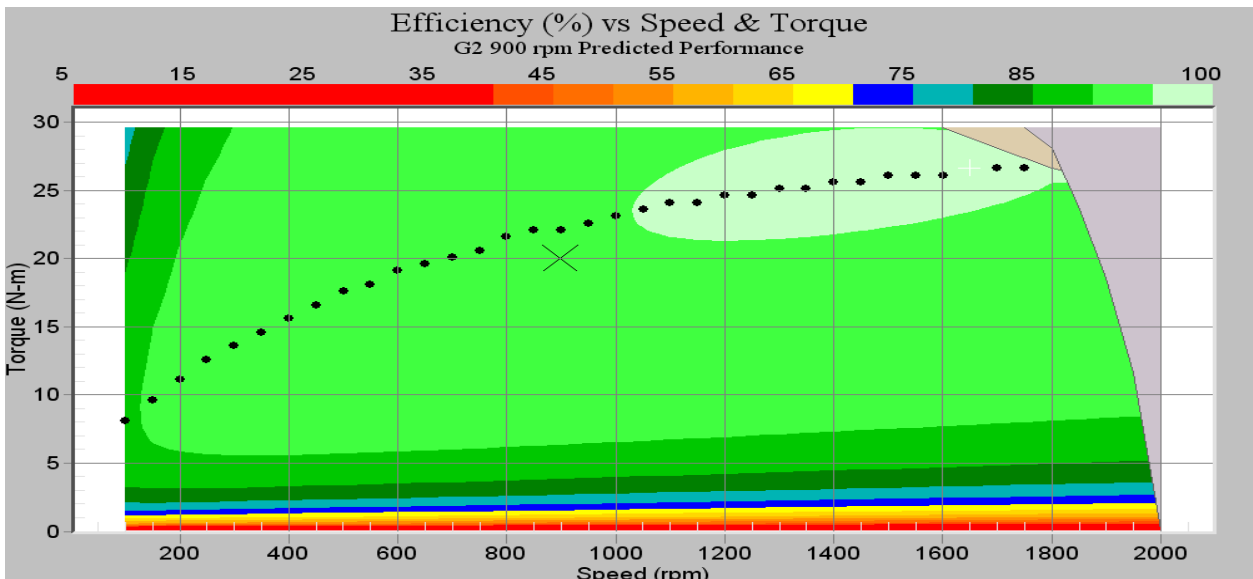

Figure 11: Predicted Motor Efficiency versus Speed and Torque for 900 RPM Motor

Efficiencies of this motor peak at [94 to 95] percent (represented by the paler shade of green in the figure above), which is remarkable for a motor of this size and weight operating at this low of a speed range. The cost of this higher efficiency is the addition of [3.5] Kg of steel from the extension of the motor length and [2] Kg of copper in the extended winding. Because the speed of this motor is so low, very little additional speed loss is introduced with the additional magnetic path length.

## **CONCLUSION**

Figure 12 illustrates the estimated performance of these two motor designs with respect to the current NEMA Premium efficiency standard and the IE3 and IE4 proposed efficiency standards for 1800 RPM motors. The standards for 900 RPM motors have even lower efficiency requirements. This makes the 1.87 Kilowatt, 900 RPM motor stand out as especially efficient compared with the existing motor standard. It is believed that this motor will exceed all of the currently proposed energy efficiency standards for electric motors.

### **Figure 12: NEMA Premium Efficiency and IE3 Standards and Predicted Motor Efficiency**

From the discussion above, it can be seen that axial motor designs have some outstanding characteristics that are particularly attractive for the construction of highly efficient electric motors. In particular, a flux concentrating design using interior ferrite permanent magnets can make a highly efficient, compact motor using low cost materials. This improvement in motor technology is capable of greatly improving the efficiency of motor driven systems, even beyond the level of the IE4 proposed standard, while avoiding the supply source issues of rare earth magnets.